

Distributed By

PA**PROTECTOR ALARMS (UK) Ltd.**20/22 GIPSY HILL
CRYSTAL PALACE
LONDON. SE19 1NL

TEL No. 020 8761 3771

FAX No. 020 8670 9441

email: sales@protectoralarms.com
Website: www.ProtectorAlarms.com

XP95 INPUT/OUTPUT UNIT WITH ISOLATOR

FUNCTION

The XP95 Input/Output Unit with Isolator provides two voltage-free, single pole, change-over relay outputs, a single monitored switch input and an unmonitored, non-polarised opto-coupled input.

FEATURES

The Input/Output Unit supervises one or more normally-open switches connected to a single pair of cables. It is set to return an analogue value of 4 in the event of an open or short-circuit fault and 16 during normal operation. The status of the inputs is reported by means of two input bits.

The change-over contacts are operated by an output bit in the protocol.

The Input/Output Unit is fitted with a bi-directional short-circuit isolator and will be unaffected by loop short-circuits on either loop input or output.

ELECTRICAL CONSIDERATIONS

The XP95 Input/Output Unit is loop powered and operates at 17-28V DC with protocol voltage pulses of 5-9V.

PROTOCOL COMPATIBILITY

The unit will operate only with control equipment using the Apollo Series 90, XP95 or Discovery protocol.

PROTOCOL BIT USAGE

The control equipment transmits a 10-bit message to the Input/Output Unit:

The **output (or forward command) bits** from the control panel have the following function:



Part no 55000-847

Output bits 2 and 1 are not used.

When output bit 0 is set to logic 1 on two or more consecutive pollings, the relay changes state to the "set" condition. Bit 0 must be set to logic 1 as long as it is desired to keep the relay in its set state. The relay will remain latched in the set state until output bit 0 is set to logic 0 on two or more consecutive pollings. Removal of loop power will cause a "set" relay to "reset".

During normal operation, the relay changes state within 0.1 second of receipt of a command.

The **seven bits** which are then transmitted by the control panel correspond to the **address (as set on the DIL switch)** of the device to be polled.



© Apollo Fire Detectors Limited 2000 - 2005



INVESTOR IN PEOPLE



Assessed to ISO 9001: 2000
Quality Systems Certificate number 010



A response message is then sent by the Input/Output Unit to the control equipment:

The **interrupt bit** is always set to logic '0'.

The **analogue value bits** are set to return a pre-set analogue value of 4 during open or short-circuit faults and 16 when the switch is open or closed. Full details are shown in the table opposite.

The **input bits** have the following function:

Input bit 2 is not used.

Input bit 1 is used to report the status of the opto-coupled input. If the voltage on this input is less than 1V, input bit 1 is set to '0'. If the input voltage is greater than 4V, input bit 1 is set to '1'. At input voltages between 1 and 4V the input is indeterminate; input bit 1 may be either '0' or '1'.

Input bit 0 is used to report the status of the monitored switch input. During normal operation, ie, when the switch is open, and in the event of a fault (open or short-circuit), input bit 0 is set to '0'. When the switch is closed, input bit 0 is set to '1'. Details of input conditions are given in the table opposite.

The **type bits** are used to identify the type of unit responding. The type code of the Input/Output Unit is 010 00 (bits 2, 1, 0, 4, 3 respectively). Bits 2, 1 and 0 are sent immediately after the input bits and bits 4 and 3 are sent in the XP protocol extension.

The Input/Output Unit sends **seven bits** of data to confirm its **address** and then **one bit** to indicate that the device can use the XP95 protocol (**XP95 flag**).

The **alarm flag** is not placed by the Input/Output Unit.

The next **two bits** returned by the device are bits 4 and 3 of the type code.

The next **five bits** are the second block of analogue value data bits and are not used by the Input/Output Unit.

The **parity bit** is set to '1' or '0' such that the device will always respond with an even number of data bits.

The **final seven bits** are the '**alarm/interrupt address**' and are not used by the Input/Output Unit.

MECHANICAL CONSTRUCTION

The Input/Output Unit is normally supplied with a backbox for surface mounting. It is also available without the backbox for flush mounting. Both versions are designed for indoor use only.

Four LEDs, two red and two yellow, are visible through the front cover of the enclosure.

One red LED is illuminated to indicate that the relay is set. The second red LED is illuminated to indicate that the switch input is closed.

One yellow LED is illuminated whenever a fault condition (open or short circuit) has been detected.

The other LED is illuminated whenever the built-in isolator has sensed a short-circuit loop fault.

The enclosure is moulded from the same white self-extinguishing polycarbonate as Apollo detectors.

Dimensions and weight of Input/Output Unit (surface mount):

150 x 90 x 48mm

240g

Schematic Diagram and Wiring Connections

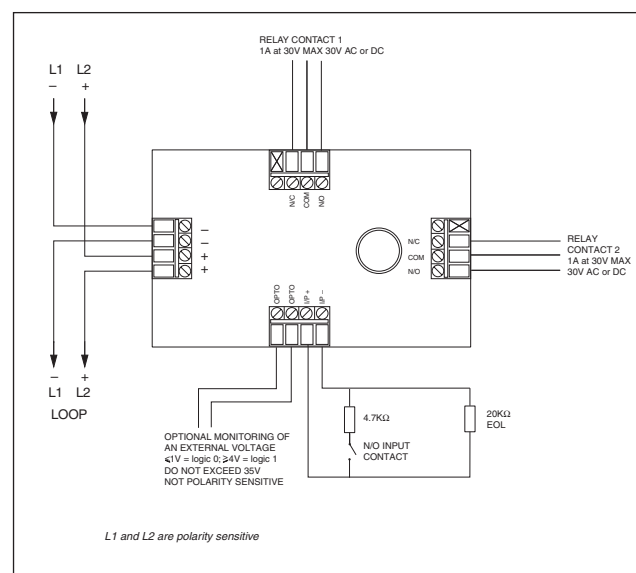

Input conditions and status

Resistance across input	Status	Analogue value	Input Bit		
			2	1	0
<100Ω	Short-circuit fault	4	0	†	0
100–200Ω	Indeterminate	4 or 16	0	†	0 or 1
200–11kΩ	Switch closed	16	0	†	1
11–15kΩ	Indeterminate	16	0	†0	or 1
15–25kΩ	Normal	16	0	†	0
25–30kΩ	Indeterminate	4 or 16	0	†	0
>30kΩ	Open-circuit fault	4	0	†	0

*The values in *italics* are recommended values. †See 'input bit 1' opposite

Technical data

Minimum loop operating voltage in normal conditions	17V DC
Maximum loop operating voltage	28V DC
Maximum current consumption at 24V DC no protocol	
Switch-on surge, max 150ms	3.5mA
Quiescent, 20kΩ EOL fitted	1.25mA
Switch input closed 'switch closed' LED on	2.5mA
Switch input closed (LED disabled)	1.5mA
Any other condition (max 2 LEDs on)	3.5mA
Relay operated	2mA
Switch input monitoring voltage (open-circuit condition)	9–11V DC
Maximum cable resistance	50Ω
Opto-coupled input maximum voltage	35V DC
impedance	10kΩ
Relay output contact rating	
1A at 30V AC or DC (inductive or resistive)	
Relay output wetting current at 10mV DC	10μA
On resistance	0.2Ω
Maximum continuous current	
1A	
Maximum switching current	3A

Maximum load	20 XP95/Discovery detectors
Operating temperature	–20°C to +70°C
Humidity (no condensation)	0–95%
Shock	} to GEI 1-052
Vibration	
Impact	
IP rating	54
Radiated and conducted RF emissions	to BS EN 50081–1 & 2
Radiated and conducted RF immunity	to BS EN 50130–4
	
LOW VOLTAGE DIRECTIVE 73/23/EEC	
No electrical supply greater than 50V AC rms or 75V DC should be connected to any terminal of this Input/ Output Unit.	
EMC DIRECTIVE 89/336/EEC	
The XP95 Input/Output Unit complies with the essential requirements of the EMC directive 89/336/EEC, provided that it is used as described in this PIN sheet and that the contact is not operated more than five times a minute or twice in any two seconds.	